

### Dimmer Specifications:

P/N: L-WLD-2WAL-xx (Dimmer w/ Cradle)  
 Operating Voltage: 3V CR1620 or CR1625 battery  
 Working Frequency: 916.5 MHz  
 RF Remote Distance: 15m (50 ft.)

### Receiver Specifications:

P/N: L-WLD-1REC  
 Input Voltage: 12VDC  
 Output Voltage: 12VDC  
 Max-Output Load: 5A, 60W  
 Dimming Range: 100% - 1%

# Installation Instructions

## FREEDiM Wireless Wall Dimmer

Two Zone • 12VDC 60W Capacity

### READ ALL INSTRUCTIONS BEFORE INSTALLING SYSTEM.

Before beginning installation, be sure power is turned OFF to light system.

FREEDiM Wall Dimmers control all Tresco® dimmable low voltage LED lights. They are wireless and can be positioned wherever you want – within 15m (50 ft.) of the lights to be controlled.

The Wall Dimmer's **mounting cradle** (see Figure 1) allows installation directly to drywall or to a standard wall electrical box, giving the appearance of a hardwired wall switch. (see Figure 2 for installation options)

The Wall Dimmer has a magnet to hold it within the mounting cradle or to place on a refrigerator. To remove Wall Dimmer from mounting cradle use the slight indents on the top and bottom edges of dimmer.

**NOTE:** The mounting cradle has an index tab to orient the Wall Dimmer in the proper "up" position. (see Figure 1)

### Installing Dimmer Receiver:

1. Disconnect Mounting Block from 12VDC Tresco® Power Supply (see spec guide for power supply options).
2. Connect **Dimmer Receiver** to Tresco® 12VDC Power Supply by snapping the output wire of the power supply (female AMP® connector) to the input wire of the receiver (male AMP® connector) (Figure 3).

Then connect **Dimmer Receiver** to mounting block by snapping the output wire of the receiver (female AMP® connector) to the input wire of the mounting block (male AMP® connector) (Figure 3).

**NOTE:** To use multiple Receivers on one power supply, connect the input wire of the Mounting Block to the power supply output and then plug the receivers into the Mounting Block. Connect lights to each receiver directly or connect an additional Mounting Block (P/N: L-TRANS-MNT-BL) to Receiver.

3. Plug desired light(s) into the Mounting Block.
4. Plug polarized 2-prong end of Tresco 12VDC power supply cord into 120V receptacle. If receptacle is operated by on/off wall switch, turn switch on after plugging power supply in.

### Programming Instructions:

1. Remove the Wall Dimmer from the Mounting Cradle (Figure 1). Remove the clear plastic tab to activate the battery.
2. Press once (do not hold down) the Learning Key (Figure 4) on the Dimmer Receiver, then press "up" once on the Wall Dimmer button left or right paddle. The lights should flash on/off, indicating they are paired up and programmed properly.
  - To increase the light(s), press and hold the "up" portion of Dimmer.
  - To dim the light(s), press and hold the "down" portion of Dimmer.
  - To turn on, tap the "up" portion of Dimmer once.
  - To turn off, tap the "down" portion of the Dimmer once.
3. Repeat step 2 for any additional Receivers or Dimmers to program.

**NOTE:** Each Receiver can be controlled by up to 8 different Dimmers. A single zone can control up to 10 Receivers. (see Figures #5 and #6 on reverse side)

### How to Deprogram a Receiver:

1. Hold down the Learning Key on the Dimmer Receiver until the lights connected to the receiver flash on/off twice.
2. The receiver is now reset and is no longer programmed to any dimmers.

## IMPORTANT SAFETY INSTRUCTIONS

**CAUTION:** To reduce the risk of fire, electric shock, or injury to persons:

- Route and secure cords so they will not be pinched or damaged.
- Use only insulated staples or plastic ties to secure ALL loose cords.
- Replace battery with a CR1620 or CR1625 battery only. Not rechargeable.
- Use Class 2 or LPS 12VDC Power Supply only to power the Receiver
- 12VDC 60W 5AMP max Receiver output
- Use only in dry locations. Not for use where exposed to the weather
- The Receiver is not intended for recessed installation in ceilings or soffits.
- A licensed electrician should be consulted for wiring through ceilings, soffits, or walls.
- All wiring must follow NEC regulations.

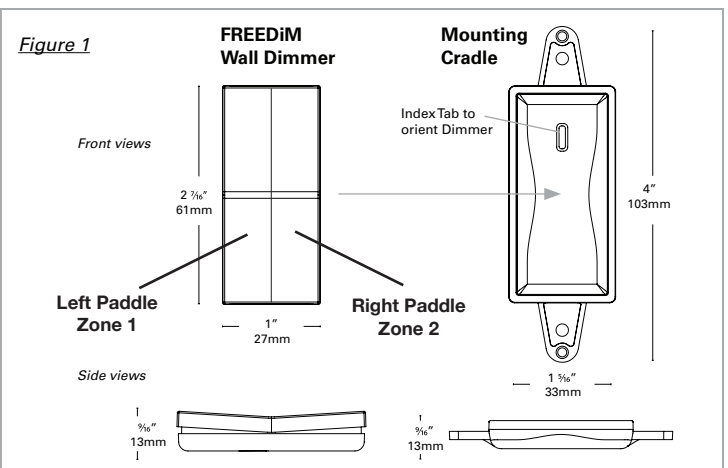

Figure 2

### Options to Install Mounting Cradle in a Wall

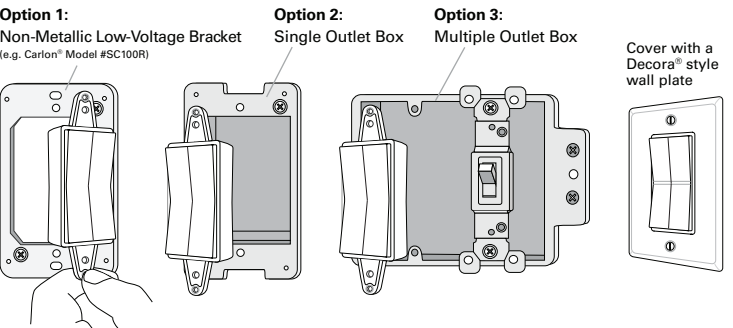

Figure 3

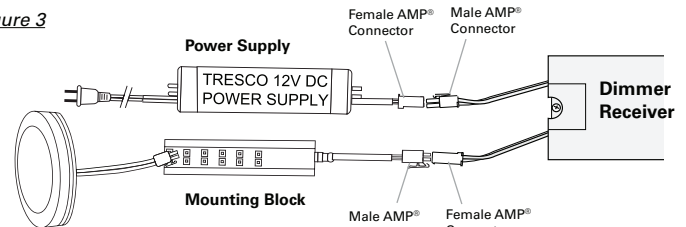
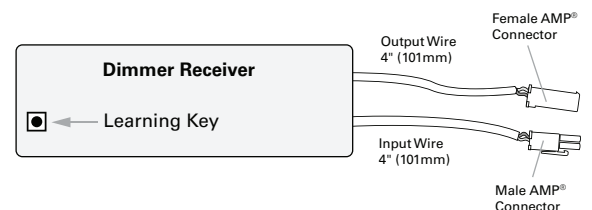

Figure 4



Save these instructions for future reference.  
 For technical assistance, call 1-800-227-1171



**Tresco Lighting by Rev-A-Shelf**  
 12400 Earl Jones Way  
 Louisville, KY 40299

Tel: 800-227-1171  
 Fax: 502-491-2215

Email: [cservice@trescolighting.com](mailto:cservice@trescolighting.com)  
 Web: [www.trescolighting.com](http://www.trescolighting.com)



# Installation Instructions

## FREEDiM Wireless Wall Dimmer

Two Zone • 12VDC 60W Capacity

**Figure 5** Each Receiver can be controlled by up to 8 different Dimmers.

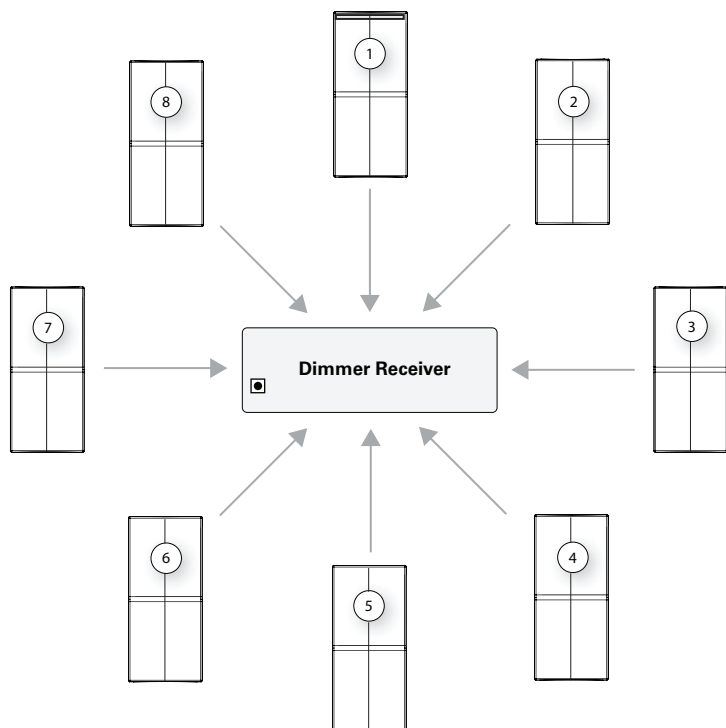

**Figure 6** Each Dimmer can control up to 10 different Receivers per zone.

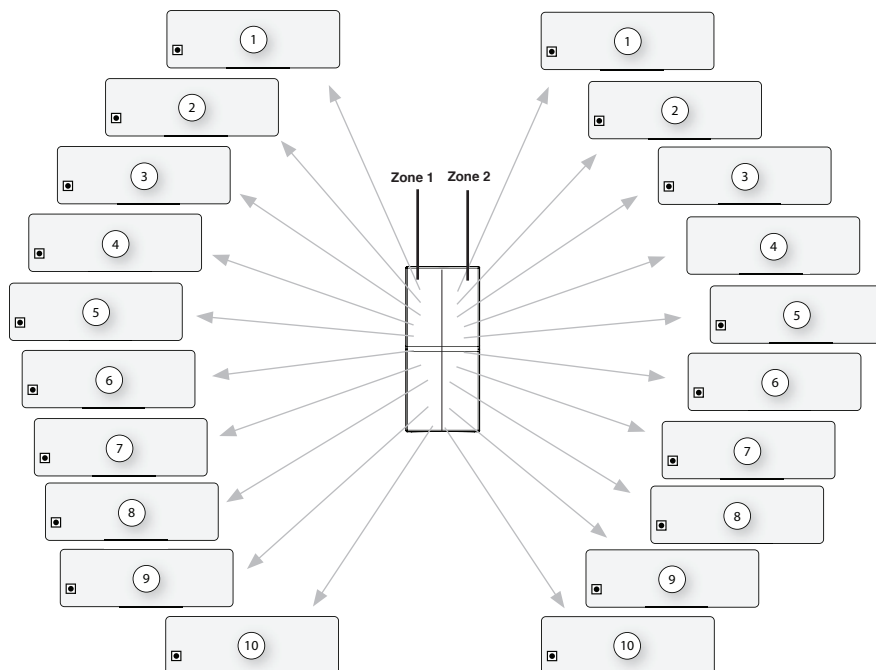

**WARNING:**  
**Chemical Burn Hazard. Keep batteries away from children.**  
 This product contains a lithium button/coin cell battery. If a new or used lithium button/coin cell battery is swallowed or enters the body, it can cause severe internal burns and can lead to death in as little as 2 hours. Always completely secure the battery compartment. If the battery compartment does not close securely, stop using the product, remove the batteries, and keep it away from children. If you think batteries might have been swallowed or placed inside any part of the body, seek immediate medical action.

*Note: Please be sure to dispose of old batteries properly, including keeping them away from children. Even used lithium button/coin cell batteries may cause injury.*

**Save these instructions for future reference.**  
**For technical assistance, 1-800-227-1171**



**Tresco Lighting by Rev-A-Shelf**  
 12400 Earl Jones Way  
 Louisville, KY 40299

Tel: 800-227-1171  
 Fax: 502-491-2215

Email: [cservice@trescolighting.com](mailto:cservice@trescolighting.com)  
 Web: [www.trescolighting.com](http://www.trescolighting.com)